

EJOT Self Drilling Screw JT2H-DP3-3PUFH #12-14xL



Product Specifications

- > Threads Per Inch: 14
- > Head Style: Phillips Undercut Flathead
- > Material: Alloy Steel ASTM A29 dual heat treated Grade 5
- > Drill Capacity: 0.036"-0.175"
- > Thread Major Dia: 0.215" (5.46 mm)
- > Thread Minor Dia: 0.164" (4.17 mm)
- > Corrosion protection: Salt spray 1000 hrs without red rust per ASTM B117

Installation and Application

1. Do not use impact drivers.
2. The fasteners can be engaged in a steel substrate using a #3 Phillips drive bit and a clutch screw gun. The fastener should be installed with 0-2000 rpm max. Be cautious as not to over drive the fastener and make sure that the thread is engaged with the base material.
3. To have enough penetration, ensure that first three full threads behind the drill point protrude through the base material.

Storage

Fasteners should be stored in the original packaging.

Precautions

Always use eye protection to reduce safety risks.

Product Properties

Steel gauge	Ultimate Pull Out Strength (lbf)	Steel gauge	Ultimate Pullover Strength (lbf)	Ultimate Tensile Test Strength (lbf)
22ga	259	20ga	804	2998
14ga	870	14ga	2164	Ultimate Shear Strength (lbf)
3/16"	2949	3/16"	2649	1937

EJOT Self Drilling Screw JT2H-DP3-3PUFH #12-14xL

Product Properties

Steel gauge	Lap shear (lbf)
11G/26G	294
11G/18G	1701
14G/26G	373
14G/18G	1545
14G/12G	2166
18G/26G	435
18G/18G	1184
18G/12G	1715
22G/26G	470
22G/18G	1202
22G/12G	906
26G/26G	297
26G/18G	333
26G/12G	457

Product Available Lengths and SKU #s

Description	Length (L) Inch	Thread Length (L1) inch	SKU #
12-14 X 1	1	Fully Threaded	3555559373
12-14 X 1-1/4	1-1/4	Fully Threaded	3555559374
12-14 X 1-1/2	1-1/2	Fully Threaded	3555559375

Product Drawing

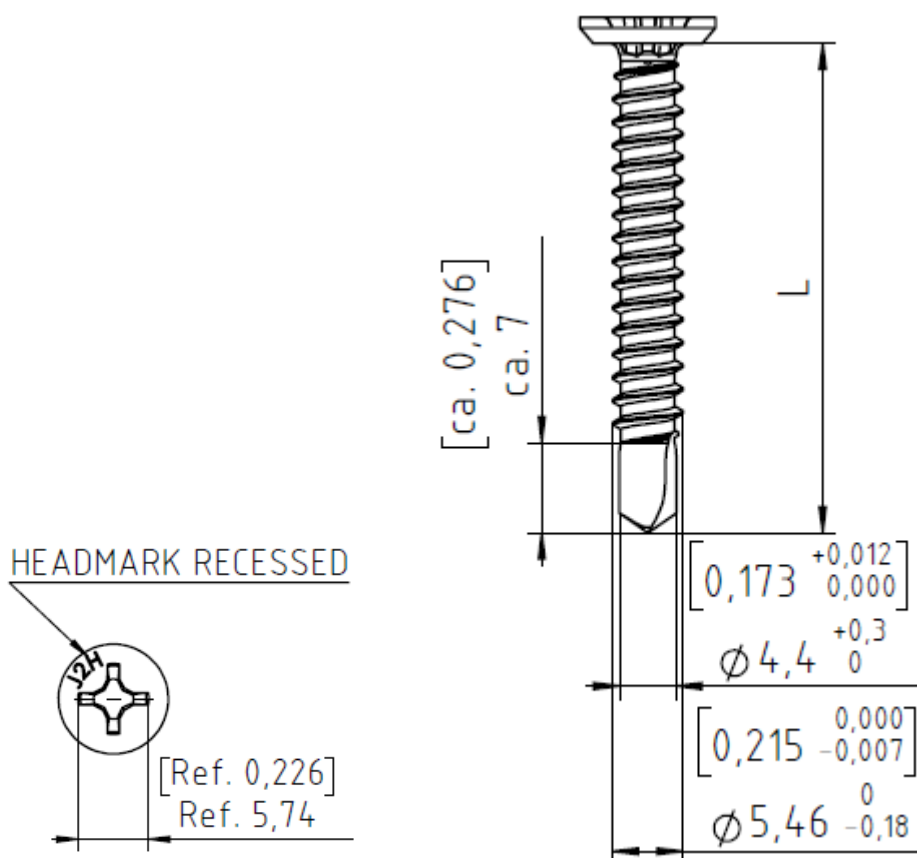

The data sheet highlights EJOT products and specifications. The mentioned values are subject to change without notice and are based on tested samples that may vary within applicable tolerances. EJOT takes responsibility for ensuring that the quality materials meets published EJOT product specifications. EJOT does not accept any liability for structural failure or resultant damages. A structural engineer should be consulted with before installation to ensure structural soundness or structural ability. No EJOT representative is authorized to vary this disclaimer.

Self drilling screw JT2H

Applications and Properties

- > JT2 is designed to drill quickly, easily, and consistently into 0.036" to 0.187"
- > Available in lengths from 3/4" to 1-1/2" and is available with DB/s extra thick 5 micron electro zinc plating or in DB's Mag Life Coating
- > Available with or without our EPDM Sealing Washer bonded to Galvanized Steel back to help prevent leaks.



Article number	Size	Head Diameter (inch)	Drill Point	Head Size	Head Style	Drilling Capacity (inch)
355558352	10-16 X 3/4	0.400	3	5/16	Hex	0.036-0.175
355558355	10-16 X 1-1/2	0.400	3	5/16	Hex	0.036-0.175
355558356	10-16 X 2	0.400	3	5/16	Hex	0.036-0.175
355558357	10-16 X 2-1/2	0.400	3	5/16	Hex	0.036-0.175
355559352	10-16 X 3/4	0.370	3	2	PPH	0.036-0.175
355559362	10-16 X 3/4	0.470	3	2	PWH	0.036-0.175
355559364	10-16 X 1-1/4	0.470	3	2	PWH	0.036-0.175
355558372	12-14 X 7/8	0.420	3	5/16	Hex	0.036-0.175
355558373	12-14 X 1	0.420	3	5/16	Hex	0.036-0.175
355558374	12-14 X 1-1/4	0.420	3	5/16	Hex	0.036-0.175
355558375	12-14 X 1-1/2	0.420	3	5/16	Hex	0.036-0.175
355558376	12-14 X 2	0.420	3	5/16	Hex	0.036-0.175
355558377	12-14 X 2-1/2	0.420	3	5/16	Hex	0.036-0.175
355558378	12-14 X 3	0.420	3	5/16	Hex	0.036-0.175
355558272	12-14 X 7/8	0.420	2	5/16	Hex	0.030-0.110

Self drilling screw JT2H

Article number	Size	Head Diameter (inch)	Drill Point	Head Size	Head Style	Drilling Capacity (inch)
3555558273	12-14 X 1	0.420	2	5/16	Hex	0.030-0.110
3555558274	12-14 X 1-1/4	0.420	2	5/16	Hex	0.030-0.110
3555558275	12-14 X 1-1/2	0.420	2	5/16	Hex	0.030-0.110
3555558276	12-14 X 2	0.420	2	5/16	Hex	0.030-0.110
3555559373	12-14 X 1	0.400	3	3	PUFH	0.036-0.175
3555559374	12-14 X 1-1/4	0.400	3	3	PUFH	0.036-0.175
3555559375	12-14 X 1-1/2	0.400	3	3	PUFH	0.036-0.175
3555558576	12-24 X 1-3/4	0.420	5	5/16	Hex	0.125-0.500
3555558393	1/4-14 X 1	0.500	3	3/8	Hex	0.036-0.175
3555558395	1/4-14 X 1-1/2	0.500	3	3/8	Hex	0.036-0.175
3555558396	1/4-14 X 2	0.500	3	3/8	Hex	0.036-0.175
3555558494	1/4-20 X 1-1/8	0.500	4	3/8	Hex	0.125-0.250
3555558495	1/4-20 X 1-1/2	0.500	4	3/8	Hex	0.125-0.250
3555558496	1/4-20 X 2	0.500	4	3/8	Hex	0.125-0.250
3555558497	1/4-20 X 2-1/2	0.500	4	3/8	Hex	0.125-0.250
3555558498	1/4-20 X 3-3/8	0.500	4	3/8	Hex	0.125-0.250
3555558499	1/4-20 X 4	0.500	4	3/8	Hex	0.125-0.250
3555558596	1/4-20 X 1-3/4	0.500	5	3/8	Hex	0.125-0.500
3555559498	1/4-20 X 3	0.460	4	3	PUFH	0.125-0.250
3555559499	1/4-20 X 4	0.460	4	3	PUFH	0.125-0.250
3555558405	5/16-24 X 1-1/2	0.520	4	3/8	Hex	0.125-0.250
3555558406	5/16-24 X 2	0.520	4	3/8	Hex	0.125-0.250
3555558409	5/16-24 X 3-1/4	0.520	4	3/8	Hex	0.125-0.250

Self drilling screw JT2H

The data sheet highlights EJOT products and specifications. The mentioned values are subject to change without notice and are based on tested samples that may vary within applicable tolerances. EJOT takes responsibility for ensuring that the quality materials meets published EJOT product specifications. EJOT does not accept any liability for structural failure or resultant damages. A structural engineer should be consulted with before installation to ensure structural soundness or structural ability. No EJOT representative is authorized to vary this disclaimer.