



ETA-Danmark A/S
Göteborg Plads 1
DK-2150 Nordhavn
Tel. +45 72 24 59 00
Fax +45 72 24 59 04
Internet www.etadanmark.dk

Authorised and notified according
to Article 29 of the Regulation (EU)
No 305/2011 of the European
Parliament and of the Council of 9
March 2011

MEMBER OF EOTA



European Technical Assessment ETA-24/0547 of 2024/07/24

I General Part

Technical Assessment Body issuing the ETA and designated according to Article 29 of the Regulation (EU) No 305/2011: ETA-Danmark A/S

Trade name of the construction product:

Fastening Screws JT, JZ and JF for fastening of wall brackets

Product family to which the above construction product belongs:

Fastening screws for metal members and sheeting

Manufacturer:

EJOT SE & Co. KG
Market Unit Construction
In der Stockwiese 35
57334 Bad Laasphe
Internet www.ejot.de/bau

Manufacturing plant:

EJOT Production Plants

This European Technical Assessment contains:

16 pages including 11 annexes which form an integral part of the document

This European Technical Assessment is issued in accordance with Regulation (EU) No 305/2011, on the basis of:

EAD 330046-01-0602, Fastening Screws for Metal Members and Sheeting

This version replaces:

Translations of this European Technical Assessment in other languages shall fully correspond to the original issued document and should be identified as such.

Communication of this European Technical Assessment, including transmission by electronic means, shall be in full. However, partial reproduction may be made, with the written consent of the issuing Technical Assessment Body. Any partial reproduction has to be identified as such.

II SPECIFIC PART OF THE EUROPEAN TECHNICAL ASSESSMENT

1 Technical description of the product

The fastening screws for metal members and sheeting (self-drilling screws) are made of steel. The fastening screws are completed with a metallic washer and an EPDM sealing washer. The fastening screws for metal members and sheeting are made of a bimetal combination of austenitic stainless with drill bits made of carbon steel.

Table 1 – Fastening screws of the corresponding ETA and their field of application

Annex	Fastening screw	Component I	Component II
5	JF3-(FR)-2-6,0xL E16	Wall brackets according to ETA-21/0756	S235
	JF6-(FR)-2-6,0xL E16		S280GD to S350GD
6	JT3-(FR)-2(H)-Plus-5,5xL E16	Wall brackets according to ETA-21/0756	S235 to S275
	JT6-(FR)-2(H)-Plus-5,5xL E16		S280GD to S450GD HX350LAD to HX460LAD
7	JT3-(FR)-6-5,5xL E16	Wall brackets according to ETA-21/0756	S235 to S355
	JT6-(FR)-6-5,5xL E16		S280GD to S350GD HX350LAD to HX460LAD
8	JT3-12-5,5xL E16	Wall brackets according to ETA-21/0756	S235 to S355
	JT6-12-5,5xL E16		S280GD to S350GD HX350LAD to HX460LAD
9	JZ1-6,3xL E16	Wall brackets according to ETA-21/0756	S235 to S355
	JZ3-6,3xL E16		S280GD to S450GD
	JZ5-6,3xL E16		HX350LAD to HX460LAD
10	JF3-Plus-6,8xL E16	Wall brackets according to ETA-21/0756	Timber C24
	JF6-Plus-6,8xL E16		Glued laminated timber GL24c/h
11	JT3-2-6,5xL E16	Wall brackets according to ETA-21/0756	Timber C24
	JT6-2-6,5xL E16		Glued laminated timber GL24c/h

2 Specification of the intended use in accordance with the applicable EAD (hereinafter referred to as EAD)

The fastening screws are intended to be used for fastening metal sheeting made of steel according to EN 10346 or aluminium alloy according to EN 485 or EN 573 to substructures made of steel according to EN 10025 or EN 10346, aluminium alloy according to EN 485 or EN 573 or structural timber according to EN 14081. The sheeting can either be used as wall or roof cladding or as load bearing wall and roof element. The fastening screws can also be used for the fastening of any other thin gauge metal members. The intended use comprises fastening screws and connections for indoor and outdoor applications.

Fastening screws which are intended to be used in external environments with \geq C2 corrosion according to the standard EN ISO 12944-2 are made of stainless steel. Furthermore, the intended use comprises connections with predominantly static loads (e.g. wind loads, dead loads). The fastening screws are not intended for re-use.

The performances given in Section 3 are only valid if the fastening screws are used in compliance with the specifications and conditions given in Annex 1 to 23.

The provisions made in this European Technical Assessment are based on an assumed intended working life of the screws of 25 years.

The indications given on the intended working life cannot be interpreted as a guarantee given by the producer or the Technical Assessment Body, but are to be regarded only as a means for selecting the appropriate products in relation to the expected economically reasonable working life of the works.

The real working life might be, in normal use conditions, considerably longer without major degradation affecting the Basic requirements for construction works.

3 Performance of the product and references to the methods used for its assessment

Performances of the fasteners, related to the basic requirements for construction works (hereinafter BWR), were determined according to EAD 330046-01-0602.

These performances, given in the following paragraphs, are valid as long as the components are the ones described in § 1 and Annexes 1 to 23 of this ETA.

Characteristic	Assessment of characteristic
3.1 Mechanical resistance and stability (BWR 1) Shear Resistance of the Connection Tension Resistance of the Connection Design Resistance in case of combined Tension and Shear Forces (interaction) Check of Deformation Capacity in case of constraining forces due to temperature Durability	See Annexes 5-11 to this ETA See Annexes 5-11 to this ETA See Annex 2 to this ETA See Annex 2 to this ETA See Annex 5 to 11, material of the fasteners
3.2 Safety in case of fire (BWR2) Reaction to fire	The screws are made from steel classified as Euroclass A1 in accordance with EN 13501-1 and Commission Delegated Regulation 2016/364

4 Assessment and verification of constancy of performance (hereinafter AVCP) system applied, with reference to its legal base

4.1 AVCP system

According to the decision 1998/214/EC of the European Commission 1, as amended by 2001/596/EC, the system of assessment and verification of constancy of performance (see Annex V to Regulation (EU) No 305/2011) is:

2+

5 Technical details necessary for the implementation of the AVCP system, as provided for in the applicable EAD

Technical details necessary for the implementation of the AVCP system are laid down in the control plan deposited at ETA-Danmark prior to CE marking.

Issued in Copenhagen on
2024-07-24 by

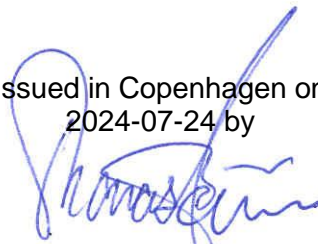

Thomas Bruun
Managing Director, ETA-Danmark

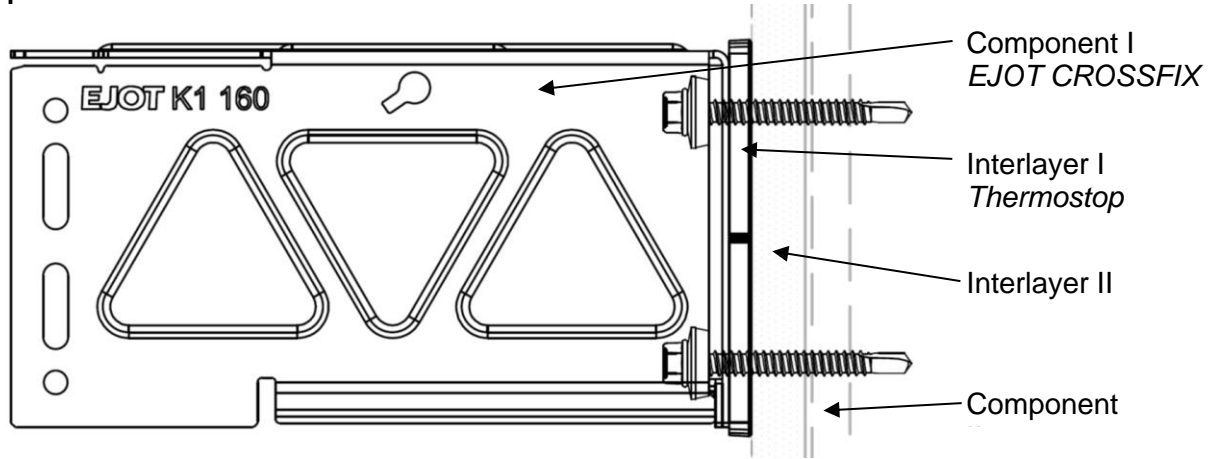
Example of the execution and the connection**Materials and dimensions**

Design relevant materials and dimensions are indicated in the annexes of the fastening screws:

Fastener	Material of the fastening screw
Washer	Material of the sealing washer
Component I	EJOT CROSSFIX stainless steel wall bracket
Component II	Material of the supporting structure
$t_{N,II}$	Thickness of component II made of metal
t_1	Thickness of component II made of timber or wood-based panel
t_{zw1}	Thickness of interlayer I, the polyamide Thermostop (5 mm)
t_{zw2}	Thickness of interlayer II, the gypsum and calcium silicate board
d_{pd}	Pre-drill diameter of component II
l_{ef}	Effective screw-in length in component II made of structural timber and OSB (without drill point)
l_b	Length of drill tip
d_{ef}	Effective diameter of the screw

The thickness $t_{N,II}$ corresponds to the load-bearing screw-in length of the fastening screw in component II, if the load-bearing screw-in length does not cover the entire component thickness.

Component I

The component to be fastened is EJOT CROSSFIX, a stainless steel bracket for fastening support structures for ventilated exterior wall cladding according to ETA-21/0756. The component has pre-punched holes and includes an interlayer made of polyamide called Thermostop with its sleeves located in the pre-punched holes. It belongs to the bracket and has been part of the testing.

Interlayer

For example, gypsum, cement and calcium silicate boards (possibly fiber-reinforced, see Table 2) can be used as interlayer in single-layer ($t_{zw2} \leq 15$ mm) or multi-layer ($t_{zw2} \leq 45$ mm) installation. Slab thicknesses of the interlayer greater than $t_{zw2} = 45$ mm are not covered.

Component II

The fastening is made to metallic supporting structures

- Steel S235 to S275 according to EN 10025-1
- S280GD to S450GD according to EN 10346
- HX350LAD to HX460LAD according to EN 10346

Or to timber or wood-based panels, for example

- Timber C24 ($\rho_k \geq 350$ kg/m³)
- Glued laminated timber GL24c/h ($\rho_k \geq 365$ kg/m³)
- Glued laminated timber made of hardwood GL70 ($\rho_k \geq 680$ kg/m³)
- Structural laminated veneer lumber LVL ($\rho_k \geq 410$ kg/m³)

Terms and explanations

Bracket fastening with JT, JF and JZ screws

Annex 1

Performance characteristics

The design relevant performance characteristics of a connection are indicated in the Annexes of the fastening screws.

$N_{R,k}$	Characteristic value of tension resistance
$V_{R,k}$	Characteristic value of shear resistance

In some cases, component-specific performance characteristics are indicated for an individual calculation in the design relevant performance characteristics of a connection:

$N_{R,II,k}$	Characteristic value of pull-out resistance for component II
$V_{R,II,k}$	Characteristic value of hole bearing resistance for component II
$M_{y,Rk}$	Characteristic value of the yield moment of the fastening screw (component II made of timber or wood-based panels)
$f_{ax,k}$	Characteristic value of the pull-out parameter for component II made of timber wood-based panels
$f_{h,k}$	Characteristic value of the hole reveal strength for structural component II made of timber or wood-based panels
$f_{h,zw2,k}$	Characteristic value of the hole reveal strength for interlayer II (gypsum and calcium silicate board)
k_{mod}	Modification coefficient for load duration and moisture content

Design values

The design values of tension and shear resistance of a connection have to be determined as following:

$N_{R,d}$	Design value of tension resistance
$V_{R,d}$	Design value of shear resistance
γ_M	Partial safety factor

The recommended partial safety factor for metallic supporting structures γ_M is 1,33, provided no partial safety factor is given in national regulations or national Annexes to Eurocode 3.

Special conditions

If the component thickness $t_{N,II}$ lies in between two indicated component thicknesses, the characteristic value may be calculated by linear interpolation.

In case of combined loading by tension and shear forces the following interaction, equation has to be taken into account:

$$\frac{N_{E,d}}{N_{R,d}} + \frac{V_{E,d}}{V_{R,d}} \leq 1,0$$

$N_{E,d}$	Design value of the applied tension forces
$V_{E,d}$	Design value of the applied shear forces

Installation conditions

- The installation is carried out according to manufacturer`s instruction.
- The load-bearing screw-in length of the fastening screw specified by the manufacturer has to be taken into account.
- The fastening screws have to be processed with suitable drill driver (e.g., cordless drill driver with depth control).
- The use of impact wrench is not allowed.
- The fastening screws have to be fixed rectangular to the surface of the component.
- The intermediate layer can, or in case of JZ screws must be, pre-drilled using the nominal (outer thread diameter) of the screw.

Performance, Installation and additional provisions

Bracket fastening with JT, JF and JZ screws

Annex 2

Component II made of timber or wood-based panels

Examples for $N_{R,II,k}$ and $V_{R,II,k}$ are indicated in the attachment of the fastening screw.

The characteristic values of the tensile and shear force bearing capacity for other k_{mod} or ρ_k than those specified in the annex of the fixing screw can be determined as follows:

$$N_{R,k} = N_{R,II,k} * k_{mod} \quad V_{R,k} = V_{R,II,k} * k_{mod}$$

The resistance of component I is not decisive.

$N_{R,II,k}$ is indicated in the annex of the fastening screw or can be calculated according to EN 1995-1-1:2010-12 + A1:2013, equation (8.40a), with $f_{ax,k}$ according to the annex of the relevant fastening screw.

$V_{R,II,k}$ is indicated in the annex of the fastening screw or can be calculated according to EN 1995-1-1:2010-12 + A1:2013, equation (8.9) and equation (8.10), with $M_{y,Rk}$ according to the annex of the relevant fastening screw and $f_{h,k}$ according to EN 1995-1-1:2012 + A1:2013, equation (8.15) and equation (8.16).

Bearing resistance of component II

The equations for determining the characteristic values of the bearing resistance have been compiled in Table 1. The self-drilling screws in this approval can be considered as pre-drilled due to their drill point.

Material	Equation	Reference
Solid wood	$f_{h,k} = 0,082 * (1 - 0,01 * d_{ef}) * \rho_k$	EN 1995-1-1:2010-12, eq. (8.16)
Glulam and laminated timber	$f_{h,k} = 0,082 * (1 - 0,01 * d_{ef}) * \rho_k$	EN 1995-1-1:2010-12, eq. (8.16)
Boards made of long, flat, aligned chips (OSB)	$f_{h,k} = 50 * d_{ef}^{-0,6} * t^{0,2}$	-
Solid wood panels	$f_{h,k} = 0,082 * (1 - 0,01 * d_{ef}) * \rho_k$	EN 1995-1-1:2010-12, eq. (8.16)

Table 1: Characteristic values of the hole bearing resistance for pre-drilled screws

Bearing resistance for interlayers

The equations for determining the characteristic hole reveal strength of the interlayer are compiled in Table 2 and 3; they apply under the assumption that the axis of the fastener is perpendicular to the panel plane. When using self-drilling screws, the interlayer can be assumed to be pre-drilled.

Material	Equation	Reference
Gypsum boards according to DIN 18180	$f_{h,zw} = 3,9 * d_{ef}^{-0,6} * t^{0,7}$	-
Fibre-reinforced gypsum boards	$f_{h,zw} = 7,0 * d_{ef}^{-0,7} * t^{0,9}$	ETA-03/0050
Cement-bonded chipboard according to EN 634-2 and DIN EN 13986	$f_{h,zw} = (75 + 1,9 * d) * d^{-0,5} + \frac{d}{10}$	-
FERMACELL Powerpanel HD	$f_{h,zw} = 37 * d^{-0,5}$	ETA-13/0609
OSB/3 according to EN 300	$f_{h,zw} = 50 * d^{-0,6} * t^{0,2}$	EN 300

Table 2: Characteristic values for hole bearing capacity of the interlayer

Calculation for timber or wood-based substrates	Annex 3
Bracket fastening with JT, JF and JZ screws	

Bearing resistance for a connection between the (undisplaceable) thin interlayer and component II made of timber or wood-based panels

Determination of the hole reveal strength in component II as well as in the interlayers and formation of a floating joint between the clip and the interlayer ($\gamma_M = 1.2$)

$$\delta_1 = \frac{f_{h,zw1}}{f_{h,k}} \quad \delta_2 = \frac{f_{h,zw2}}{f_{h,k}}$$

$$V_{R,II,k} = \min \left\{ \begin{array}{l} a) \quad f_{h,k} * b_1 * d + f_{h,zw2,k} * t_{zw2} * d \\ b_1 = 2 \left(\sqrt{\left(t_{zw1} + t_{zw2} + \frac{t_1}{2} \right)^2 - \delta_1 * t_{zw2} \left(t_{zw1} + \frac{t_{zw2}}{2} \right) + \delta_1 * \frac{t_{zw1}^2}{4} + \frac{t_1^2}{4} - \left(t_{zw1} + t_{zw2} + \frac{t_1}{2} \right)} \right) \\ b) \quad (f_{h,k} * b_1 * d + f_{h,zw2,k} * t_{zw2} * d) * 1,15 + 0,25 * F_{ax,\alpha,Rk} \\ b_1 = \sqrt{(t_{zw1} + t_{zw2})^2 - \delta_2 * (2 * t_{zw1} * t_{zw2} + t_{zw2}^2) + \delta_1 * \frac{t_{zw1}^2}{2} + \frac{2 * M_{y,Rk}}{f_{h,k} * d} - (t_{zw1} + t_{zw2})} \end{array} \right.$$

Those equations are only valid for positive values of b_1 . If b_1 is negative, the connection becomes one with a sliding interlayer and be designed according to the equations for thick sliding interlayers below.

Bearing resistance for no connection between the (sliding) thick interlayer and component II made of timber or wood-based panels

If the interlayer is a certain thickness, the bearing resistance of the interlayer is greater than the bearing resistance of component II. Then the bearing resistance of the connection can be assumed to be the same as that of a connection without an interlayer.

In this case it can be designed according to the following equation from EN 1995-1-1:2010-12 eq. (8.9).

$$V_{R,II,k} = \min \left\{ \begin{array}{l} 0,4 * f_{h,k} * t_1 * d \\ 1,15 * \sqrt{2M_{y,Rk} * f_{h,k} * d + \frac{F_{ax,Rk}}{4}} \end{array} \right.$$

Calculation for timber or wood-based substrates

Bracket fastening with JT, JF and JZ screws

Annex 4

	<p>Material:</p> <p>Screw: JF3 stainless steel (A2) - EN ISO 3506 JF6 stainless steel (A4) - EN ISO 3506 (Head variations FR or LT possible)</p> <p>Washer: stainless steel (A2/A4) - EN ISO 3506 With vulcanized EPDM seal</p> <p>Component I: Wall bracket incl. 5,0mm PA Thermostop Stainless steel (A2/A4) - EN 10088-2</p> <p>Component II: S280GD to S350GD according to EN 10346</p>
--	--

Table 1.1: Single-layer supporting structure made of S235 or S280GD to S350GD

	t _{N,II} [mm]	0,60	0,63	0,70	0,75	0,88	1,00	-	-	-	-	-	-
S280GD	N _{R,k,II} ¹ [kN]	1,14	1,24	1,47	1,64	1,95	2,23	-	-	-	-	-	-
	with 5,0mm Polyamid Thermostop, without additional intermediate layer												
	V _{R,k,II} [kN]	1,77	1,83	1,96	2,05	2,28	2,49	-	-	-	-	-	-
	with 5,0mm Polyamid Thermostop and additional intermediate layer ≤ 1 x 15 mm												
		0,92	0,95	1,01	1,06	1,13	1,20	-	-	-	-	-	-

¹ Für t_{N,II} from S320GD or S350GD, the values may be increased by 8.3%

Characteristic capacities of the fastener	Annex 5
JF3-(FR)-2-6,0xL E16 and JF6-(FR)-2-6,0xL E16	

Material:

Screw: JT3 stainless steel (A2) - EN ISO 3506
JT6 stainless steel (A4) - EN ISO 3506
(Head variations FR possible)

Washer: stainless steel (A2/A4) - EN ISO 3506
With vulcanized EPDM seal

Component I: Wall bracket incl. 5,0mm PA Thermostop
Stainless steel (A2/A4) - EN 10088-2

Component II: S235 to S275 according to EN 10025-1
S280GD to S450GD according to EN 10346
HX350LAD to HX460LAD according to EN 10346

Table 2.1: Single-layer supporting structure made of S235 to S275, S280GD to S450GD or HX350LAD to HX460LAD

$t_{N,II}$ [mm]	0,60	0,63	0,70	0,75	0,88	1,00	1,13	1,25	1,50	-	-	-	
S280GD	$N_{R,k,II}^1$ [kN]	0,53	0,56	0,66	0,79	1,06	1,40	1,71	1,99	2,59	-	-	-
	with 5,0mm Polyamid Thermostop, without additional intermediate layer												
		1,10	1,24	1,58	1,82	1,90	1,97	2,34	2,68	3,18	-	-	-
	with 5,0mm Polyamid Thermostop and additional intermediate layer $\leq 1 \times 15$ mm												
	$V_{R,k,II}$ [kN]	0,57	0,59	0,65	0,69	0,79	0,88	1,65	2,37	2,77	-	-	-
	with 5,0mm Polyamid Thermostop and additional intermediate layer $\leq 2 \times 15$ mm												
		0,57	0,59	0,65	0,68	0,74	0,79	1,45	2,07	2,31	-	-	-
with 5,0mm Polyamid Thermostop and additional intermediate layer $\leq 3 \times 15$ mm													
	0,57	0,59	0,64	0,67	0,68	0,69	1,25	1,76	1,84	-	-	-	

¹ For $t_{N,II}$ from S320GD to S450GD respectively HX340LAD to HX460LAD, the values may be increased by 8.3%.

Table 2.2: Two-layer supporting structure made of S235 to S275, S280GD to S450GD or HX350LAD to HX460LAD

$t_{N,II}$ [mm]	2 x 0,60	2 x 0,63	2 x 0,70	2 x 0,75	2 x 0,88	2 x 1,00	-	-	-	
S280GD	$N_{R,k,II}^{1,2}$ [kN]	-	1,01	1,46	1,78	2,31	2,84	-	-	-
	with 5,0mm Polyamid Thermostop, without additional intermediate layer									
		2,44	2,52	2,71	2,84	3,21	3,56	-	-	-
	with 5,0mm Polyamid Thermostop and additional intermediate layer $\leq 1 \times 15$ mm									
	$V_{R,k,II}$ [kN]	1,67	1,76	1,96	2,11	2,57	3,00	-	-	-
	with 5,0mm Polyamid Thermostop and additional intermediate layer $\leq 2 \times 15$ mm									
		1,67	1,76	1,96	2,11	2,34	2,55	-	-	-
with 5,0mm Polyamid Thermostop and additional intermediate layer $\leq 3 \times 15$ mm										
	1,67	1,76	1,96	2,10	2,10	2,10	-	-	-	

¹ For $t_{N,II}$ from S320GD to S450GD respectively HX340LAD to HX460LAD, the values may be increased by 8.3%.

Characteristic capacities of the fastener	Annex 6
JT3-(FR)-2(H)-Plus-5,5xL E16 and JT6-(FR)-2(H)-Plus-5,5xL E16	

Material:

Screw: JT3 stainless steel (A2) - EN ISO 3506
JT6 stainless steel (A4) - EN ISO 3506
(Head variations FR possible)

Washer: stainless steel (A2/A4) - EN ISO 3506
With vulcanized EPDM seal

Component I: Wall bracket incl. 5,0mm PA Thermostop
Stainless steel (A2/A4) - EN 10088-2

Component II: S235 to S355 according to EN 10025-1
S280GD to S350GD according to EN 10346
HX350LAD to HX460LAD according to EN 10346

Table 3.1: Single-layer supporting structure made of f S235 to S355, S280GD to S350GD or HX350LAD to HX460LAD

$t_{N,II}$ [mm]	1,50	2,00	2,50	3,00	4,00	5,00							
S280GD	$N_{R,k,II}$ [kN]	1,90	2,60	4,23	5,01	7,04	8,28						
	with 5,0mm Polyamid Thermostop, without additional intermediate layer												
		3,02	3,26	5,74	8,21	-	-						
	with 5,0mm Polyamid Thermostop and additional intermediate layer $\leq 1 \times 15$ mm												
	$V_{R,k,II}$ [kN]	2,24	3,07	4,43	5,79	-	-						
	with 5,0mm Polyamid Thermostop and additional intermediate layer $\leq 2 \times 15$ mm												
		2,06	2,48	4,14	5,79	-	-						
	with 5,0mm Polyamid Thermostop and additional intermediate layer $\leq 3 \times 15$ mm												
		1,87	1,88	3,84	5,79	-	-						

	<p>Material:</p> <p>Screw: JT3 stainless steel (A2) - EN ISO 3506 JT6 stainless steel (A4) - EN ISO 3506 (Head variations FR possible)</p> <p>Washer: stainless steel (A2/A4) - EN ISO 3506 With vulcanized EPDM seal</p> <p>Component I: Wall bracket incl. 5,0mm PA Thermostop Stainless steel (A2/A4) - EN 10088-2</p> <p>Component II: S235 to S355 according to EN 10025-1 S280GD to S350GD according to EN 10346 HX350LAD to HX460LAD according to EN 10346</p>
--	--

Table 4.1: Single-layer supporting structure made of S235 to S355, S280GD to S350GD or HX350LAD to HX460LAD

$t_{N,II}$ [mm]	4,00	5,00	≥ 6	-	-	-	-	-	-	-	-	-	
S280GD	$N_{R,k,II}^1$ [kN]	4,70	6,90	8,13	-	-	-	-	-	-	-	-	
		with 5,0mm Polyamid Thermostop, without additional intermediate layer											
		13,05	13,13	13,21	-	-	-	-	-	-	-	-	
	$V_{R,k,II}$ [kN]	with 5,0mm Polyamid Thermostop and additional intermediate layer ≤ 1 x 15 mm											
			10,39	11,83	13,27	-	-	-	-	-	-	-	-
		with 5,0mm Polyamid Thermostop and additional intermediate layer ≤ 2 x 15 mm											
			7,60	9,16	10,71	-	-	-	-	-	-	-	-
	with 5,0mm Polyamid Thermostop and additional intermediate layer ≤ 3 x 15 mm												
	4,81	6,48	8,14	-	-	-	-	-	-	-	-		

Characteristic capacities of the fastener	Annex 8
JT3-12-5,5xL E16 and JT6-12-5,5xL E16	

Material:

Screw: JZ1 stainless steel (A8) - EN ISO 3506
 JZ3 stainless steel (A2) - EN ISO 3506
 JZ5 stainless steel (A2) - EN ISO 3506

Washer: stainless steel (A2/A4) - EN ISO 3506
 With vulcanized EPDM seal

Component I: Wall bracket incl. 5,0mm PA Thermostop
 Stainless steel (A2/A4) - EN 10088-2

Component II: S235 to S355 according to EN 10025-1
 S280GD to S450GD according to EN 10346 and HX350LAD to HX460LAD according to EN 10346

Table 5.1: Single-layer supporting structure made of S235 to S355, S280GD to S450GD or HX350LAD to HX460LAD

$t_{N,II}$ [mm]	1,25	1,50	2,00	3,00	4,00	5,00	6,00	7,00	$\geq 10,00$	-	-	-	
d_{pd} [mm]	$\varnothing 5,0$		$\varnothing 5,3$				$\varnothing 5,5$	$\varnothing 5,7$	$\varnothing 5,8$	-	-	-	
$N_{R,k,II}$ ¹ [kN]	2,00	2,70	3,60	6,00	8,80	11,60	13,40	13,40	13,40	-	-	-	
S280GD	with 5,0mm Polyamid Thermostop, without additional intermediate layer												
		2,98	3,33	4,04	8,00	11,35	14,70	18,05	18,05	18,05	-	-	-
	with 5,0mm Polyamid Thermostop and additional intermediate layer $\leq 1 \times 15$ mm												
	$V_{R,k,II}$ ¹ [kN]	2,13	2,36	2,81	6,16	9,40	12,63	15,87	15,87	15,87	-	-	-
	with 5,0mm Polyamid Thermostop and additional intermediate layer $\leq 2 \times 15$ mm												
	1,85	2,09	2,56	5,27	7,18	9,09	11,00	11,00	11,00	-	-	-	
with 5,0mm Polyamid Thermostop and additional intermediate layer $\leq 3 \times 15$ mm													
	1,56	1,81	2,31	4,37	4,96	5,54	6,13	6,13	6,13	-	-	-	

¹ S275 to S355, S390GD to S450GD and HX340LAD to HX460LAD only for JZ5-6,3xL.

Characteristic capacities of the fastener	Annex 9
JZ1-6,3xL E16, JZ3-6,3xL E16 and JZ5-6,3xL E16	

Material:

Screw: JF3 stainless steel (A2) - EN ISO 3506
JF6 stainless steel (A4) - EN ISO 3506
(Head variations FR possible)

Washer: stainless steel (A2/A4) - EN ISO 3506
With vulcanized EPDM seal

Component I: Wall bracket incl. 5,0mm PA Thermostop
Stainless steel (A2/A4) - EN 10088-2

Component II: Timber C24 ($\rho_k \geq 350 \text{ kg/m}^3$)
Glued laminated timber GL24c/h ($\rho_k \geq 365 \text{ kg/m}^3$)

Table 6.1: Supporting structure made of timber and wood-based materials

The load-bearing capacities for connections with interlayers or other ρ_k and l_{ef} can be calculated using the equations in Annex 3 and 4. These load-bearing capacities were calculated as examples with the following parameters:

Component II - Timber \geq C24 or Glued laminated timber GL24c/h

C24 $\rho_k \geq 350 \text{ kg/m}^3$ / GL24 $\rho_k \geq 365 \text{ kg/m}^3$, $k_{mod,II} = 0,9$

Interlayer I (Thermostopp)

$\rho_k \geq 954 \text{ kg/m}^3$, $k_{mod,z} = 0,7$

Interlayer II (Gypsum board, EN 520)

$\rho_k \geq 954 \text{ kg/m}^3$, $k_{mod,z} = 0,6$

Properties of the fastener			
$M_{y,Rk}$ 10.774 Nmm	$f_{ax,k}$ 12,2 N/mm ² at $l_{ef} \geq 27 \text{ mm}$	Drill tip length $l_b = 9 \text{ mm}$	$d_{ef} = 5,17 \text{ mm}$

Connection with 5,0mm Polyamid Thermostop, without additional interlayer										
screw length	L [mm]	40	60	80	100	120	140	160	180	200
eff. embedment depth	l_{ef} [mm]	-	38	58	78	98	118	138	158	178
Timber \geq C24 $\rho_k \geq 350 \text{ kg/m}^3$	$N_{R,k}$ [kN]	-	2,84	4,33	5,82	7,32	-	-	-	-
	$V_{R,k}$ [kN]	-	1,14	1,76	2,22	2,22	-	-	-	-

Connection with 5,0mm Polyamid Thermostop and additional thin indisplacable interlayer $\leq 15 \text{ mm}$										
screw length	L [mm]	40	60	80	100	120	140	160	180	200
eff. embedment depth	l_{ef} [mm]	-	-	43	63	83	103	123	143	163
Timber \geq C24 $\rho_k \geq 350 \text{ kg/m}^3$	$N_{R,k}$ [kN]	-	-	3,21	4,70	6,20	7,69	-	-	-
	$V_{R,k}$ [kN]	-	-	1,34	1,74	1,74	1,74	-	-	-

Connection with 5,0mm Polyamid Thermostop and additional thick sliding interlayer $\leq 30 \text{ mm}$										
screw length	L [mm]	40	60	80	100	120	140	160	180	200
eff. embedment depth	l_{ef} [mm]	-	-	28	48	68	88	108	128	148
Timber \geq C24 $\rho_k \geq 350 \text{ kg/m}^3$	$N_{R,k}$ [kN]	-	-	2,09	3,58	5,08	6,57	-	-	-
	$V_{R,k}$ [kN]	-	-	1,11	1,90	2,69	3,18	-	-	-

Characteristic capacities of the fastener	Annex 10
JF3-Plus-6,8xL E16 and JF6-Plus-6,8xL E16	

